

Technical Data

4000 Series

4012-46TWG2A

4012-46TWG3A

Diesel Engine - ElectropaK

1800 rev/min

Basic technical data

| | |
|-----------------------|---|
| Number of cylinders | 12 |
| Cylinder arrangement | Vee 60° |
| Cycle | 4 stroke, compression ignition |
| Induction system | turbocharged |
| Combustion system | direct injection |
| Compression ratio | 13:1 |
| Bore | 160 mm |
| Stroke | 190 mm |
| Cubic capacity | 45-482 litres |
| Direction of rotation | Anti clockwise viewed on flywheel |
| Firing order | 1 ^A , 6 ^B , 5 ^A , 2 ^B , 3 ^A , 4 ^B , 6 ^A , 1 ^B , 2 ^A , 5 ^B , 4 ^A , 3 ^B |
| Cylinder 1 | furthest from flywheel |

Note: Cylinders designated 'A' are on the right hand side of the engine when viewed from the flywheel end.

Total weight of ElectropaK

| | |
|-------------------------------------|---------|
| Engine - dry | |
| -temperate | 4440 kg |
| -tropical | 4440 kg |
| ElectropaK - dry ⁽¹⁾ | |
| -temperate | 5220 kg |
| -tropical | 5283 kg |
| ElectropaK - wet ^{(1) (2)} | |
| -temperate | 5547 kg |
| -tropical | 5615 kg |

1. Includes fuel cooler.

2. Includes engine lubricating oil and water jacket

Overall dimensions of ElectropaK

| | |
|------------|---------|
| Height | 2255 mm |
| Length | 3714 mm |
| Width | |
| -temperate | 1780 mm |
| -tropical | 1978 mm |

Moment of inertia (mk²)

| | |
|----------|-----------------------|
| Flywheel | 9,57 kgm ² |
| Engine | 9,73 kgm ² |

Cyclic irregularity

For engine/flywheel maximum:

| | |
|------------------------------|--------|
| -4012-46TWG2A @ 1800 rev/min | 1:1147 |
| -4012-46TWG3A @ 1800 rev/min | 1:752 |

Ratings

Steady state speed stability at constant load $\pm 0,25\%$
 Electrical ratings are based on average alternator efficiency and are for guidance only (0.8 power factor being used).

Operating point

| | |
|--------------------------------|------------------|
| Engine speed | 1800 rev/min |
| Static injection timing | spill timing 22° |
| Cooling water exit temperature | < 98 °C |

Performance

Note: All data based on operation to ISO 3046/1, BS 5514 and DIN 6271 standard reference conditions.

Estimated sound pressure level at 1 metre 112 d(B)A

Note: Noise levels represent highest recorded at 1800 rev/min

For engines operating in ambient conditions other than the standard reference conditions stated below, a suitable de-rate must be applied.

De-rate tables for increased ambient temperatures and / or altitude are available, please contact Perkins Applications Department

Test conditions

| | |
|---|---------|
| -air temperature | 25 °C |
| -barometric pressure | 100 kPa |
| -relative humidity | 30% |
| -air inlet restriction at maximum power (nominal) | 2,5 kPa |
| -exhaust back pressure at maximum power (nominal) | 3,0 kPa |
| -maximum fuel temperature (inlet pump) | 58 °C |

For test conditions relevant to data on load acceptance, please refer to Cold start recommendations on page 22 of this document.

General installation - 4012-46TWG2A (Temperate) 60 Hz @ 1800 rev/min

| Designation | Units | Type of operation and application | | |
|--|---------------------|-----------------------------------|-------|---------|
| | | Base | Prime | Standby |
| Gross engine power | kWb | 884 | 1106 | 1217 |
| Fan and battery charging alternator power | kW | 51 | | |
| Net engine power | kWm | 833 | 1055 | 1166 |
| Brake mean effective pressure (gross) | kPa | 1286 | 1608 | 1770 |
| Combustion air flow at ISO conditions | m ³ /min | 95 | 109 | 114 |
| Exhaust gas temperature (max) after turbo | °C | 430 | | |
| Exhaust gas flow (max) at atmospheric pressure | m ³ /min | 235 | | |
| Boost pressure ratio | - | 2.40 | 2.80 | 3.00 |
| Mechanical efficiency | % | 88.0 | 90.1 | 91.0 |
| Overall thermal efficiency (nett) | % | 37.5 | 37.0 | 38.0 |
| Friction and pumping power losses | kWm | 121 | | |
| Mean piston speed | m/s | 11,4 | | |
| Engine coolant flow | l/min | 1000 | | |
| Typical GenSet electrical output (0.8pf) | kVA | 989 | 1253 | 1385 |
| | kWe | 791 | 1002 | 1108 |
| Assumed alternator efficiency | % | 95 | | |

General installation - 4012-46TWG2A (Tropical) 60 Hz @ 1800 rev/min

| Designation | Units | Type of operation and application | | |
|--|---------------------|-----------------------------------|-------|---------|
| | | Base | Prime | Standby |
| Gross engine power | kWb | 891 | 1113 | 1224 |
| Fan and battery charging alternator power | kW | 58 | | |
| Net engine power | kWm | 833 | 1055 | 1166 |
| Brake mean effective pressure (gross) | kPa | 1296 | 1619 | 1780 |
| Combustion air flow at ISO conditions | m ³ /min | 96 | 111 | 116 |
| Exhaust gas temperature (max) after turbo | °C | 435 | | |
| Exhaust gas flow (max) at atmospheric pressure | m ³ /min | 235 | | |
| Boost pressure ratio | - | 2.41 | 2.81 | 3.00 |
| Mechanical efficiency | % | 88 | 90 | 91 |
| Overall thermal efficiency (nett) | % | 37,5 | 37,0 | 38,0 |
| Friction and pumping power losses | kWm | 121 | | |
| Mean piston speed | m/s | 11,4 | | |
| Engine coolant flow | l/min | 1000 | | |
| Typical GenSet electrical output (0.8pf) | kVA | 989 | 1253 | 1385 |
| | kWe | 791 | 1002 | 1108 |
| Assumed alternator efficiency | % | 95 | | |

Notes:

- All quoted gross engine powers include an allowance of 1.5% for installation variance
- Not to be used for CHP design purposes (indicative figures only). Consult Perkins Engines Stafford Limited. Assumes complete combustion.

General installation - 4012-46TWG3A (Temperate), 60 Hz @ 1800 rev/min

| Designation | Units | Type of operation and application | | |
|--|---------------------|-----------------------------------|-------|---------|
| | | Base | Prime | Standby |
| Gross engine power | kWb | 960 | 1200 | 1314 |
| Fan and battery charging alternator power | kW | 51 | | |
| Net engine power | kWm | 909 | 1149 | 1263 |
| Brake mean effective pressure (gross) | kPa | 1396 | 1745 | 1911 |
| Combustion air flow at ISO conditions | m ³ /min | 96 | 110 | 116 |
| Exhaust gas temperature (max) after turbo | °C | 478 | | |
| Exhaust gas flow (max) at atmospheric pressure | m ³ /min | 250 | | |
| Boost pressure ratio | - | 2.60 | 3.10 | 3.30 |
| Mechanical efficiency | % | 87.0 | 90.0 | 91.0 |
| Overall thermal efficiency (nett) | % | 37.0 | 38.0 | 38.0 |
| Friction and pumping power losses | kWm | 122 | | |
| Mean piston speed | m/s | 11.4 | | |
| Engine coolant flow | l/min | 1000 | | |
| Typical GenSet electrical output (0.8pf) | kVA | 1079 | 1364 | 1500 |
| | kWe | 864 | 1092 | 1200 |
| Assumed alternator efficiency | % | 95 | | |

General installation - 4012-46TWG3A (Tropical), 60 Hz @ 1800 rev/min

| Designation | Units | Type of operation and application | | |
|--|---------------------|-----------------------------------|-------|---------|
| | | Base | Prime | Standby |
| Gross engine power | kWb | 967 | 1207 | 1321 |
| Fan and battery charging alternator power | kW | 58 | | |
| Net engine power | kWm | 909 | 1149 | 1263 |
| Brake mean effective pressure (gross) | kPa | 1406 | 1755 | 1921 |
| Combustion air flow at ISO conditions | m ³ /min | 96 | 111 | 117 |
| Exhaust gas temperature (max) after turbo | °C | 482 | | |
| Exhaust gas flow (max) at atmospheric pressure | m ³ /min | 240 | | |
| Boost pressure ratio | - | 2.60 | 3.10 | 3.30 |
| Mechanical efficiency | % | 87.0 | 90.0 | 91.0 |
| Overall thermal efficiency (nett) | % | 37.0 | 38.0 | 38.0 |
| Friction and pumping power losses | kWm | 122 | | |
| Mean piston speed | m/s | 11.4 | | |
| Engine coolant flow | l/min | 1000 | | |
| Typical GenSet electrical output (0.8pf) | kVA | 1079 | 1364 | 1500 |
| | kWe | 864 | 1092 | 1200 |
| Assumed alternator efficiency | % | 95 | | |

Notes:

- All quoted gross engine powers include an allowance of 1.5% for installation variance
- Not to be used for CHP design purposes (indicative figures only). Consult Perkins Engines Stafford Limited. Assumes complete combustion.

Rating definitions

Baseload power

Unlimited hours usage with an average load factor of 100% of the published baseload power rating.

Prime Power

Variable load. Unlimited hours usage with an average load factor of 80% of the published prime power rating over each 24 hr. period A 10% overload is available for 1 hour in every 12 hour of operation.

Standby power

Variable load. Limited to 500 hours annual usage up to 300 hours of which may be continuous running. No overload is permitted.

Emissions capability

All 4012-46TWG ratings are optimised to the 'best fuel consumption' and do not comply to Harmonised International Regulation Emission Limits. More information on these statements can be obtained by contacting the Applications Department at Perkins Engines Company Limited.

Energy balance

4012-46TWG2A - Temperate

| Designation | Units | Baseload | Prime | Standby |
|--------------------------------|-------|----------|-------|---------|
| Energy in fuel | kWt | 2157 | 2691 | 3057 |
| Energy in power output (gross) | kWb | 884 | 1106 | 1217 |
| Energy to cooling fan | kWm | 51 | | |
| Energy in power output (nett) | kWm | 833 | 1055 | 1166 |
| Energy to exhaust | kWt | 711 | 914 | 1050 |
| Energy to coolant and oil | kWt | 358 | 387 | 450 |
| Energy to radiation | kWt | 67 | 81 | 90 |
| Energy to charge cooler | kWt | 136 | 203 | 250 |

4012-46TWG2A - Tropical

| Designation | Units | Baseload | Prime | Standby |
|--------------------------------|-------|----------|-------|---------|
| Energy in fuel | kWt | 2172 | 2712 | 3084 |
| Energy in power output (gross) | kWb | 891 | 1113 | 1224 |
| Energy to cooling fan | kWm | 58 | | |
| Energy in power output (nett) | kWm | 833 | 1055 | 1166 |
| Energy to exhaust | kWt | 717 | 921 | 1055 |
| Energy to coolant and oil | kWt | 359 | 389 | 457 |
| Energy to radiation | kWt | 67 | 84 | 96 |
| Energy to charge cooler | kWt | 138 | 205 | 252 |

4012-46TWG3A - Temperate

| Designation | Units | Baseload | Prime | Standby |
|--------------------------------|-------|----------|-------|---------|
| Energy in fuel | kWt | 2319 | 2940 | 3322 |
| Energy in power output (gross) | kWb | 960 | 1200 | 1314 |
| Energy to cooling fan | kWm | 51 | | |
| Energy in power output (nett) | kWm | 909 | 1149 | 1263 |
| Energy to exhaust | kWt | 767 | 1010 | 1150 |
| Energy to coolant and oil | kWt | 363 | 407 | 480 |
| Energy to radiation | kWt | 72 | 90 | 100 |
| Energy to charge cooler | kWt | 157 | 232 | 278 |

4012-46TWG3A - Tropical

| Designation | Units | Baseload | Prime | Standby |
|--------------------------------|-------|----------|-------|---------|
| Energy in fuel | kWt | 2302 | 2920 | 3344 |
| Energy in power output (gross) | kWb | 967 | 1207 | 1321 |
| Energy to cooling fan | kWm | 58 | | |
| Energy in power output (nett) | kWm | 909 | 1149 | 1263 |
| Energy to exhaust | kWt | 755 | 995 | 1155 |
| Energy to coolant and oil | kWt | 355 | 400 | 490 |
| Energy to radiation | kWt | 71 | 88 | 100 |
| Energy to charge cooler | kWt | 154 | 229 | 278 |

Note: Not to be used for combined heat and power (CHP) purposes (indicative figures only), if required, please consult Perkins Engines Company Limited.

Exhaust system

Outlet size (internal) 2 x 254 mm
 Outlet flange size 10" table D
 Back pressure for total system... .. 5.0 kPa
 For recommended pipe sizes, refer to the Installation Manual.

Induction system

Emissions data with combustion air temperature of 25 °C

Maximum air intake restriction of engine:

-clean filter 2.0 kPa
 -dirty filter 4.0 kPa
 -air filter type cylindrical paper pleat

4012-46TWG2A Temperate - left view

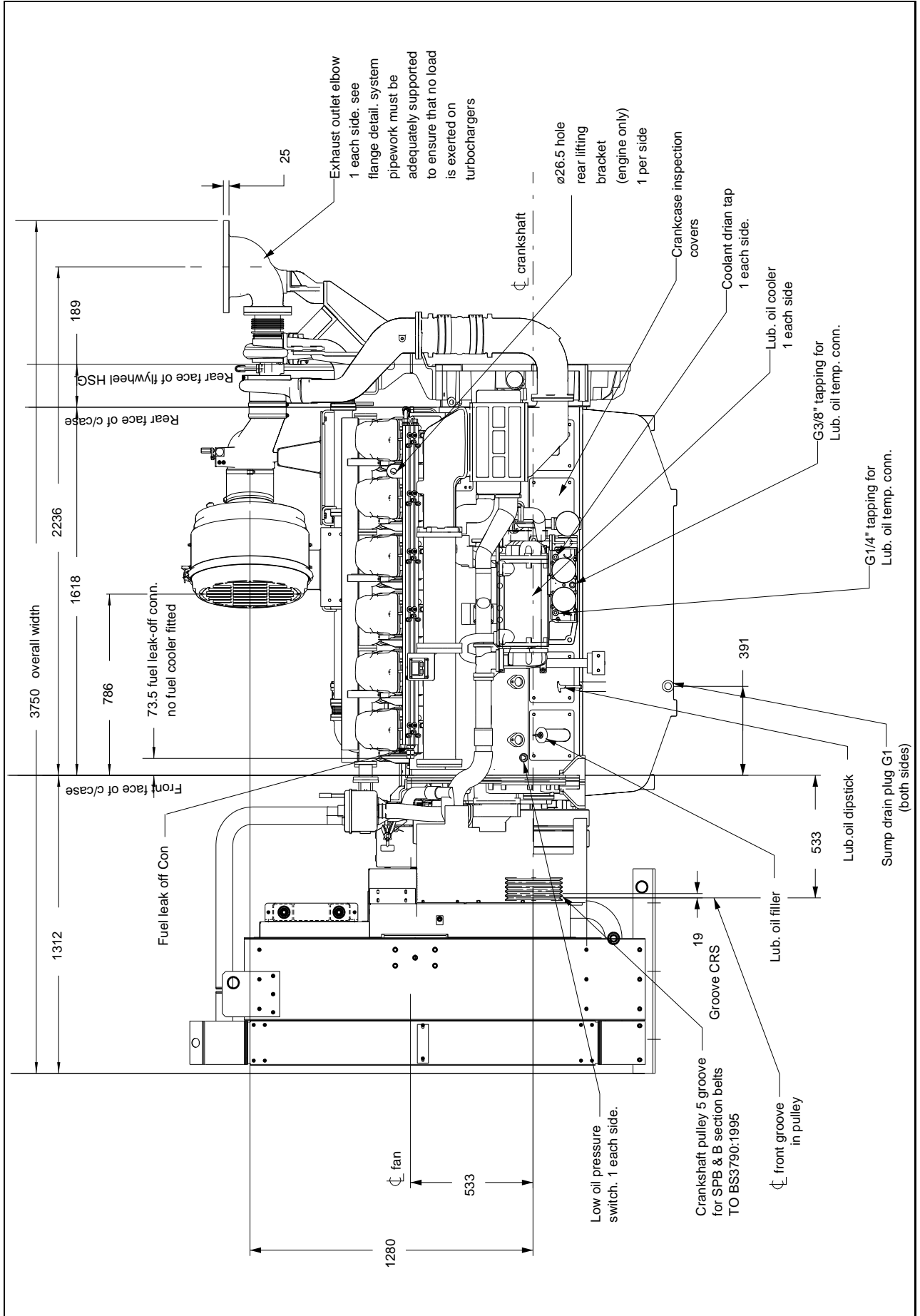

4012-46TWG2A Temperate - front view

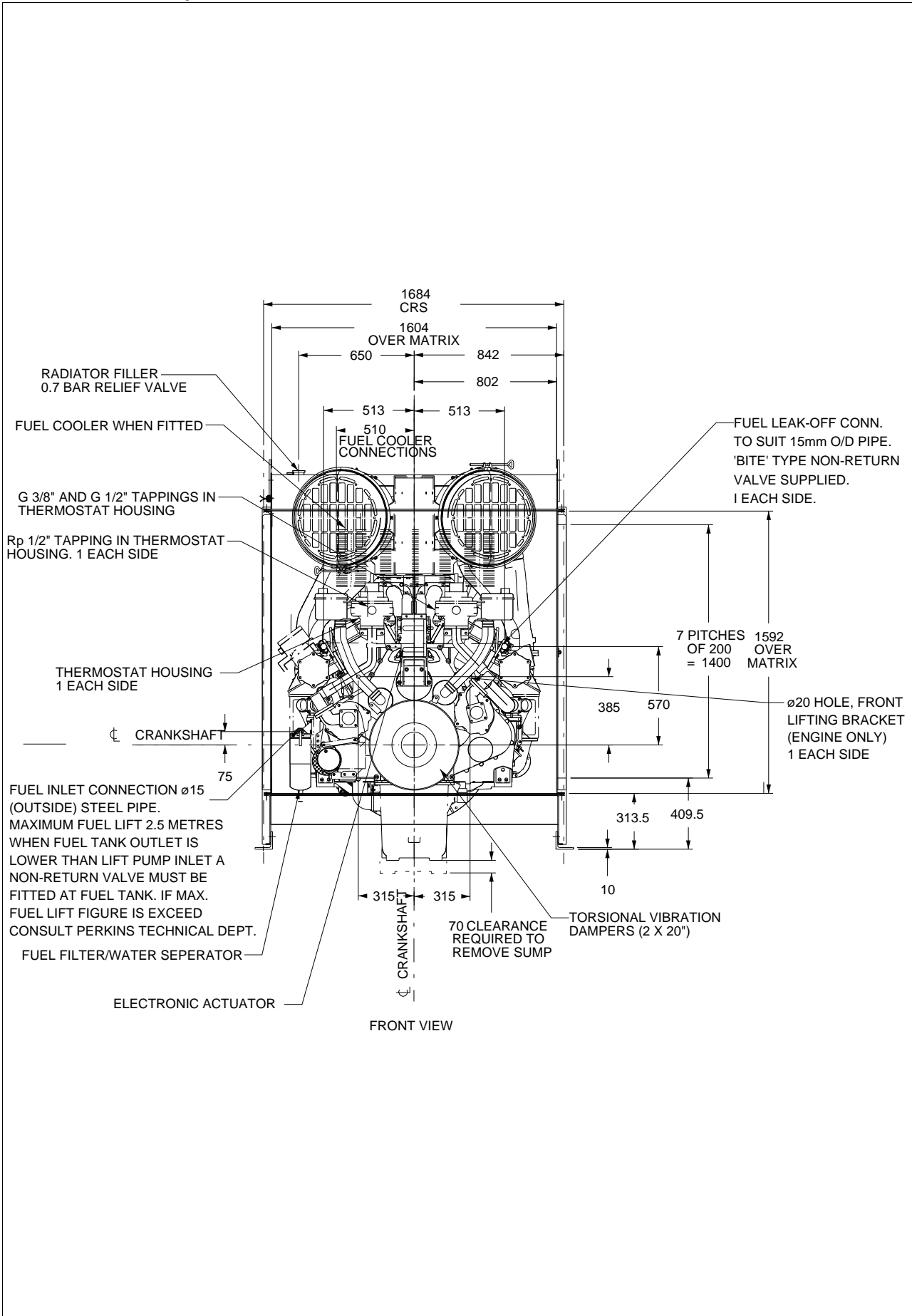

4012-46TWG2A Temperate - right view

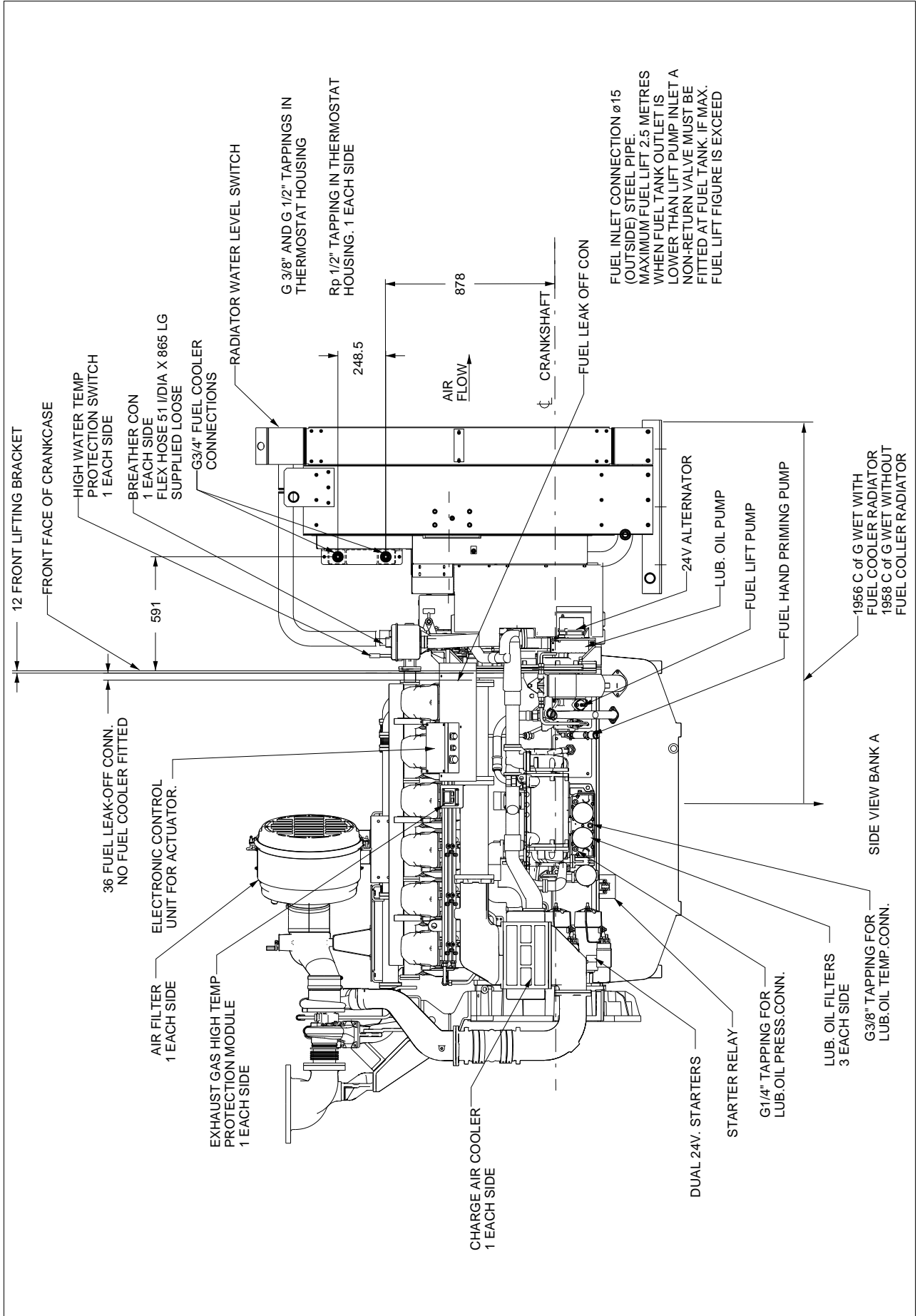

4012-46TWG2A Temperate - rear view

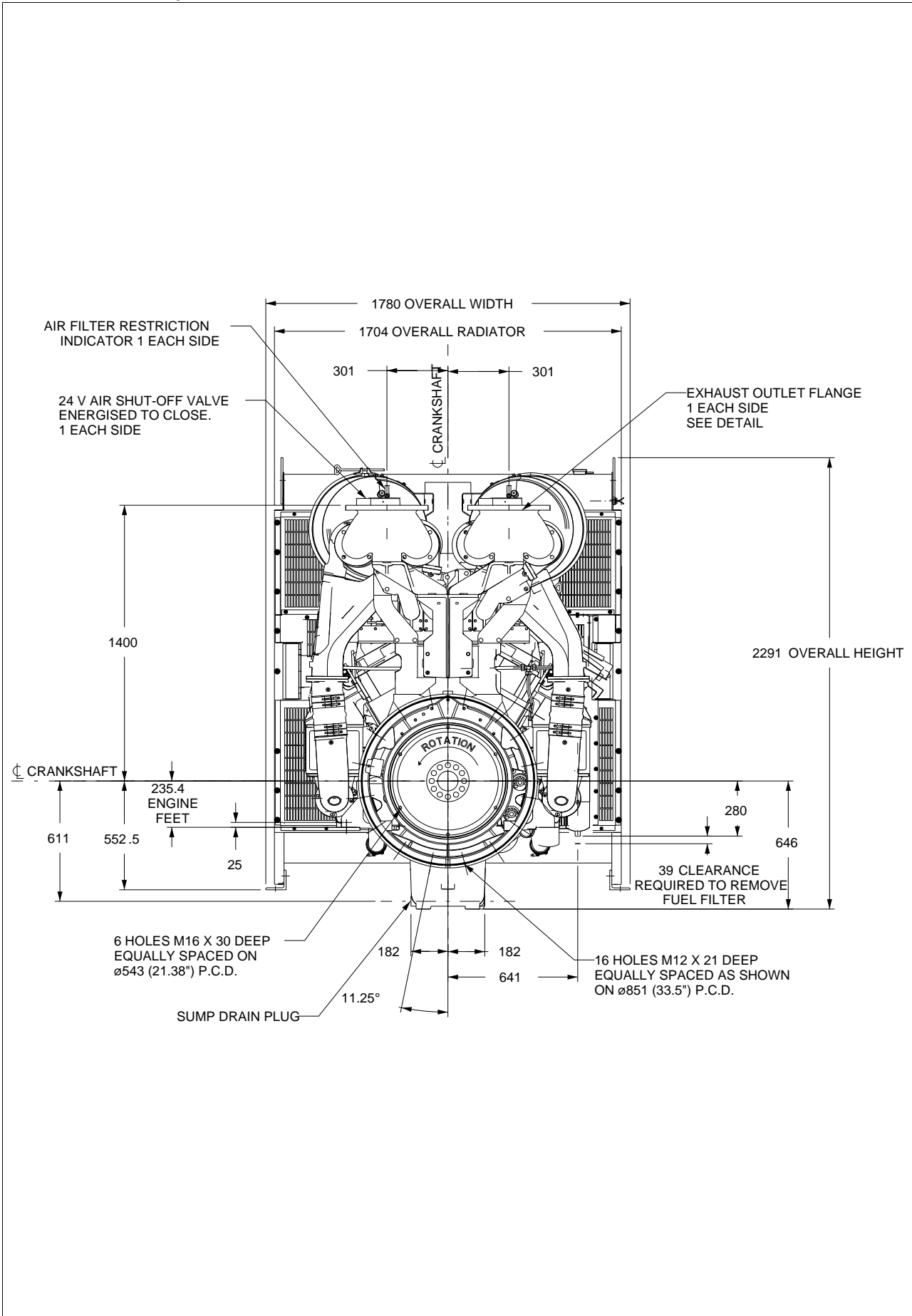

4012-46TWG2A Temperate - Support pads, exhaust outlet flange and flywheel detail

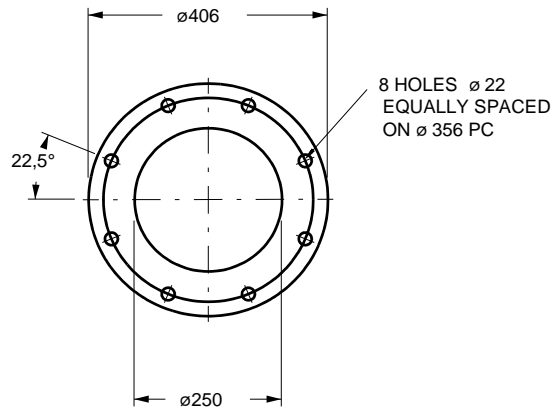

DETAIL OF EXHAUST OUTLET FLANGE
(B.S.10 TABLE D)
SCALE 1:5

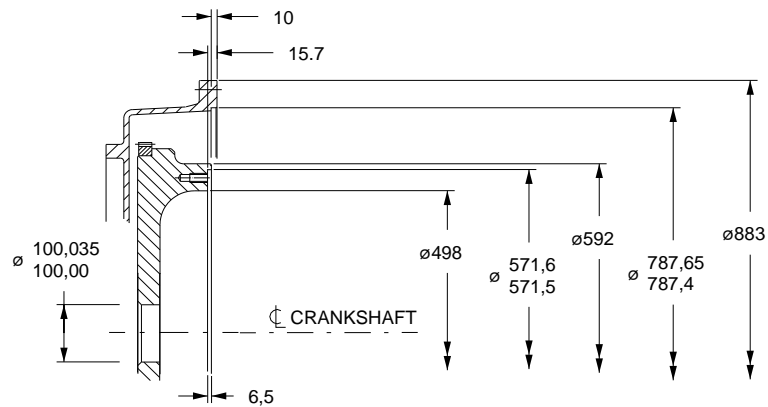

DETAIL OF SAE 518 FLYWHEEL
AND SAE 00 FLYWHEEL HOUSING
(METRIC TAPPINGS)
SCALE 1:5

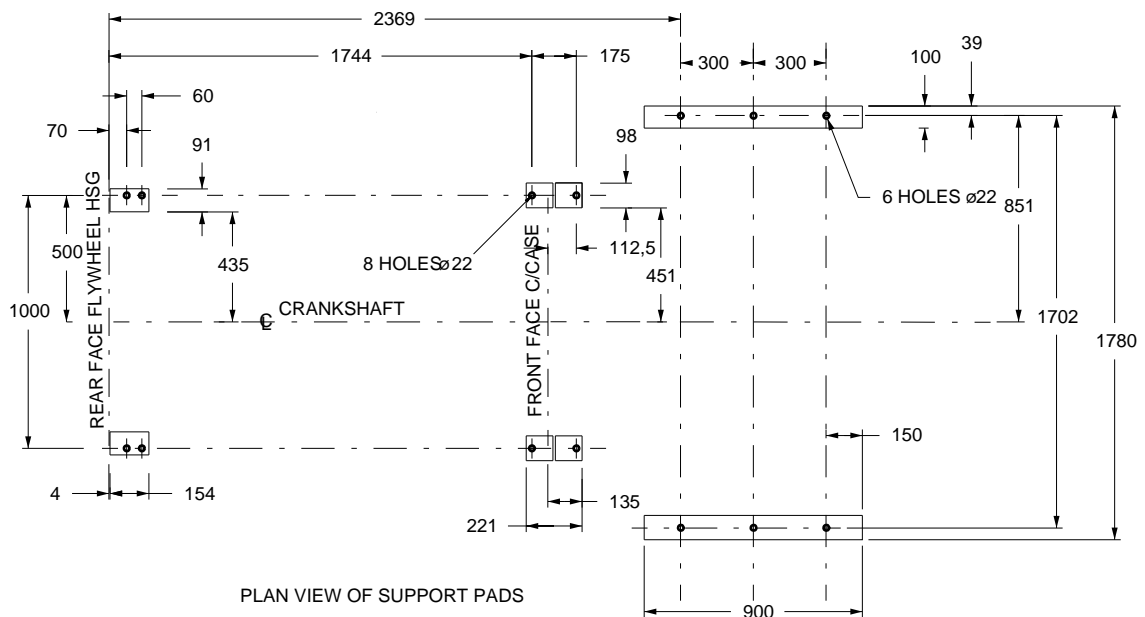

4012-46TWG2A Tropical - 4012-46TWG3A Temperate - left view

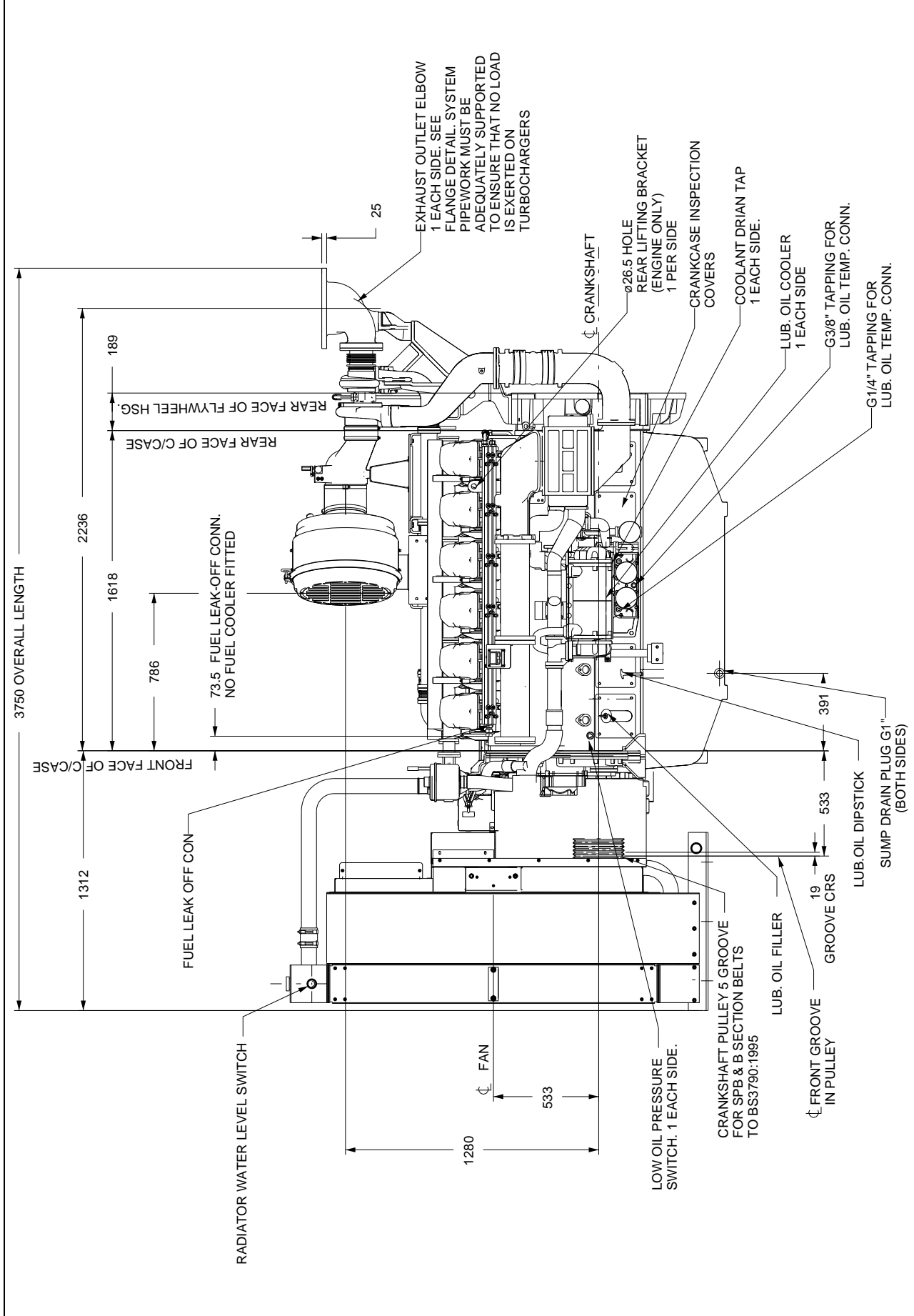

4012-46TWG2A Tropical - 4012-46TWG3A Temperate - front view

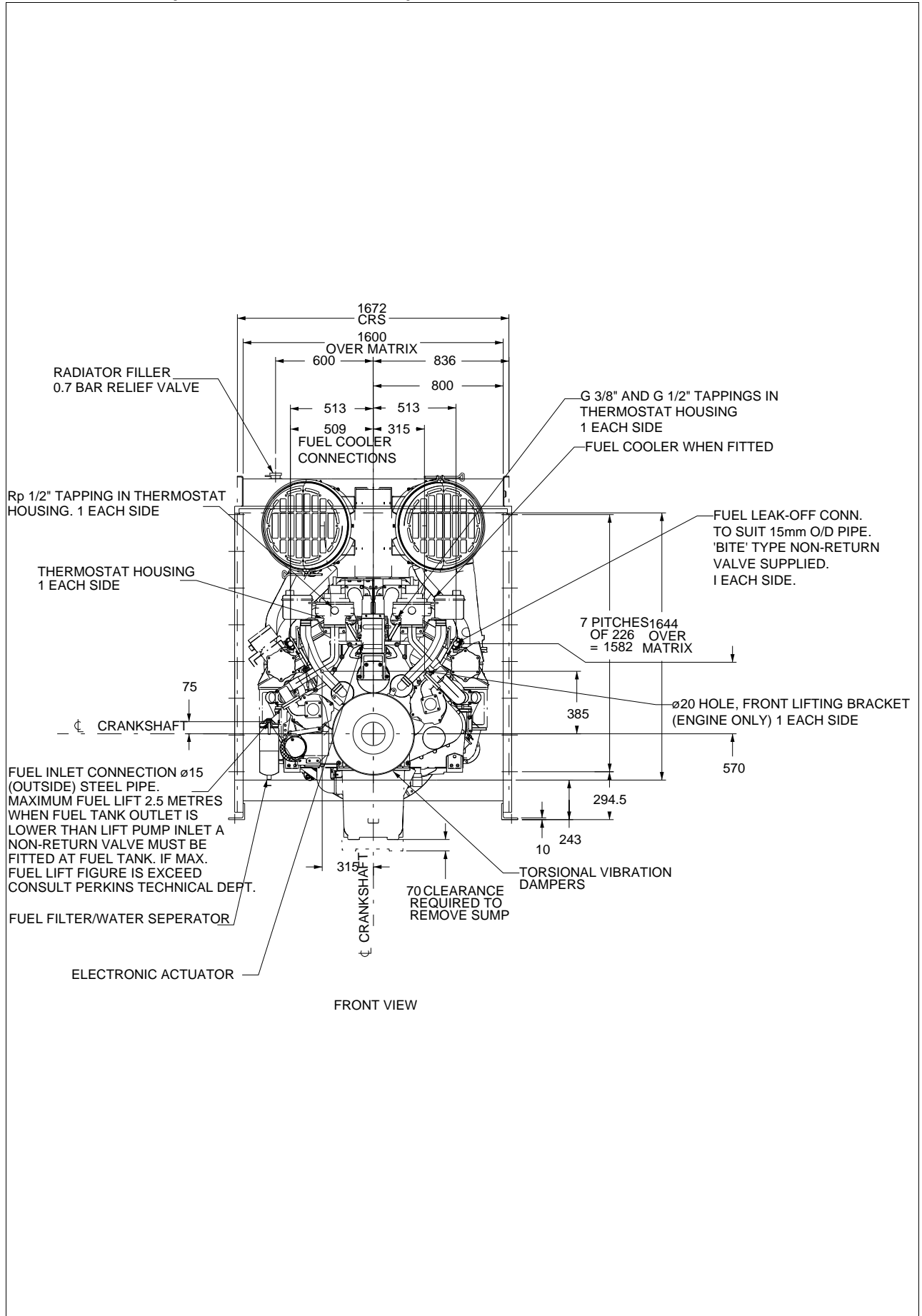

4012-46TWG2A Tropical - 4012-46TWG3A Temperate - right view

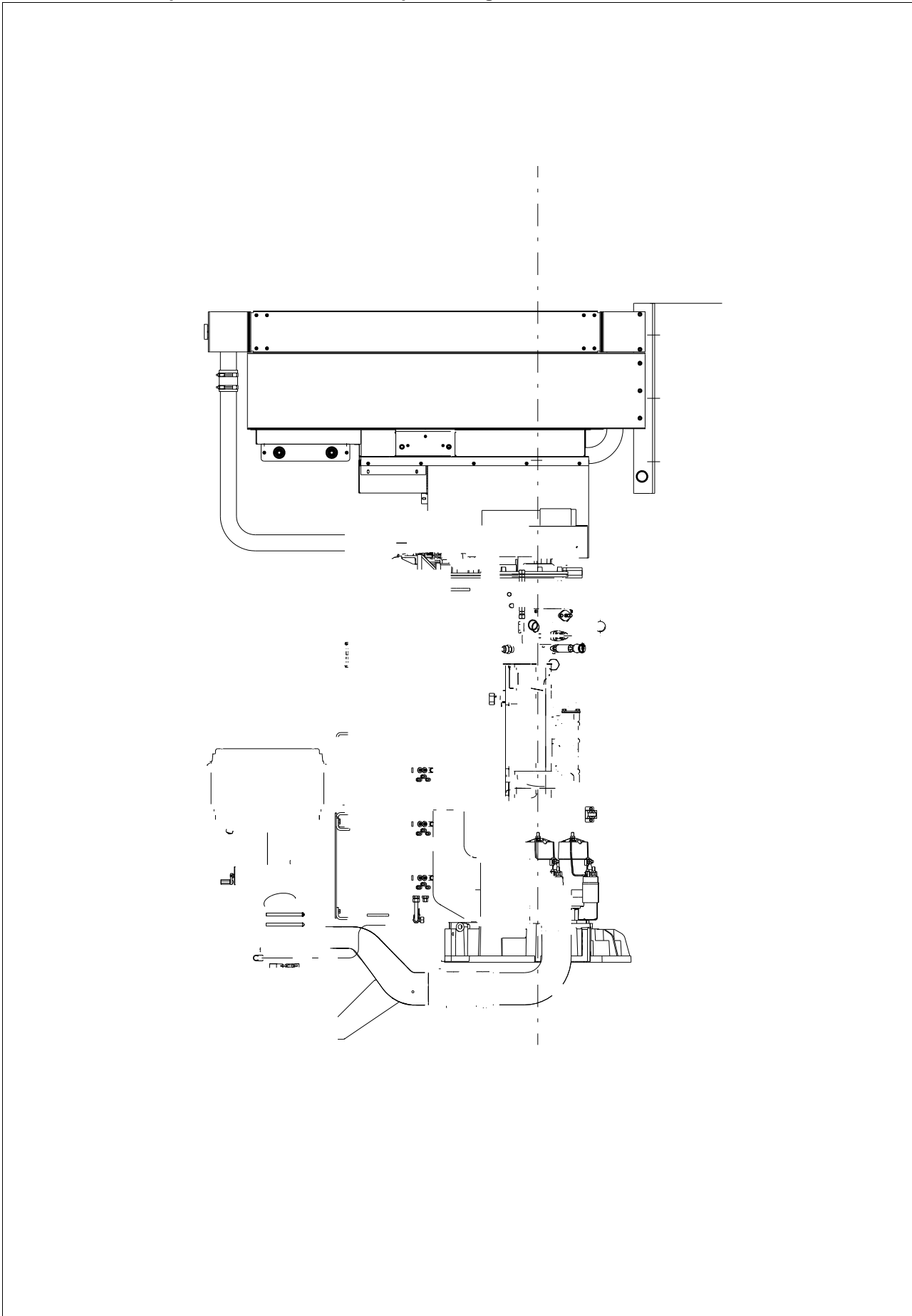

4012-46TWG2A Tropical - 4012-46TWG3A Temperate- rear view

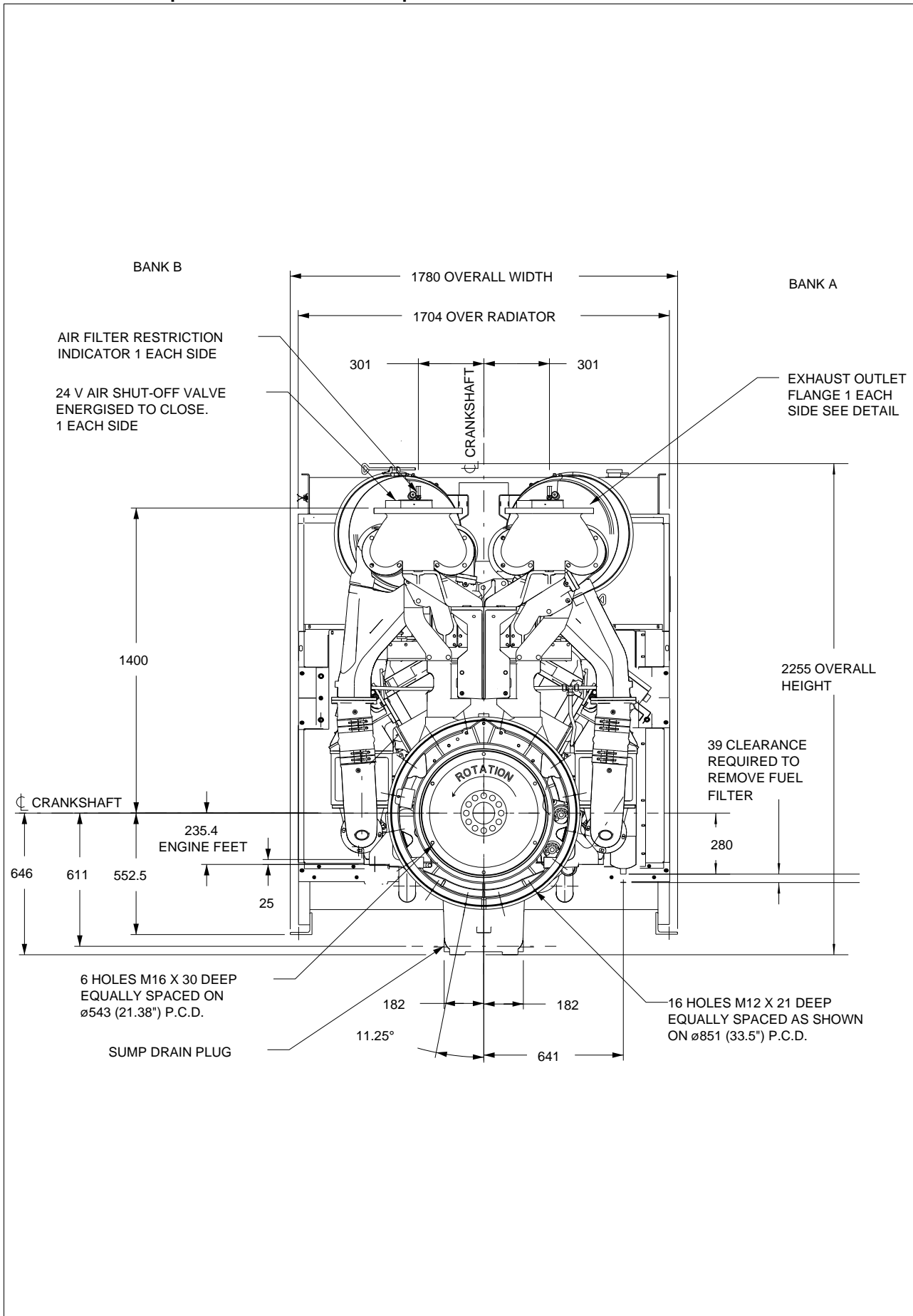

4012-46TWG2A Tropical - 4012-46TWG3A Temperate - Support pads, exhaust outlet flange and flywheel detail

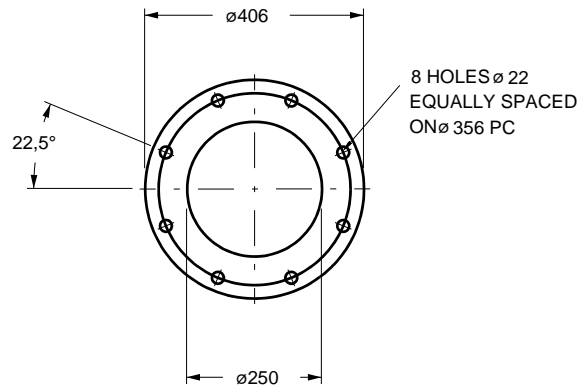

DETAIL OF EXHAUST OUTLET FLANGE
(B.S.10 TABLE D)
SCALE 1:5

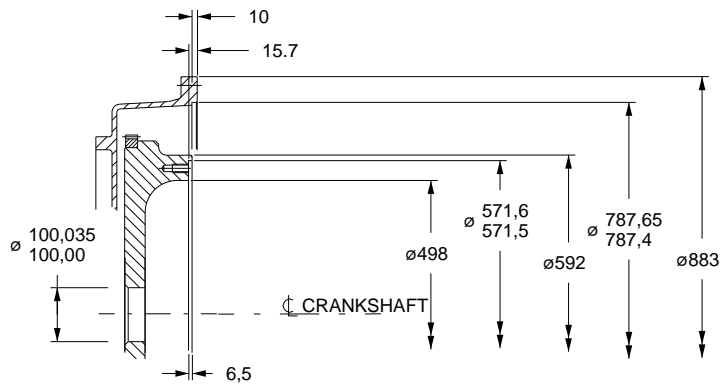

DETAIL OF SAE 518 FLYWHEEL
AND SAE 00 FLYWHEEL HOUSING
(METRIC TAPPINGS)
SCALE 1:5

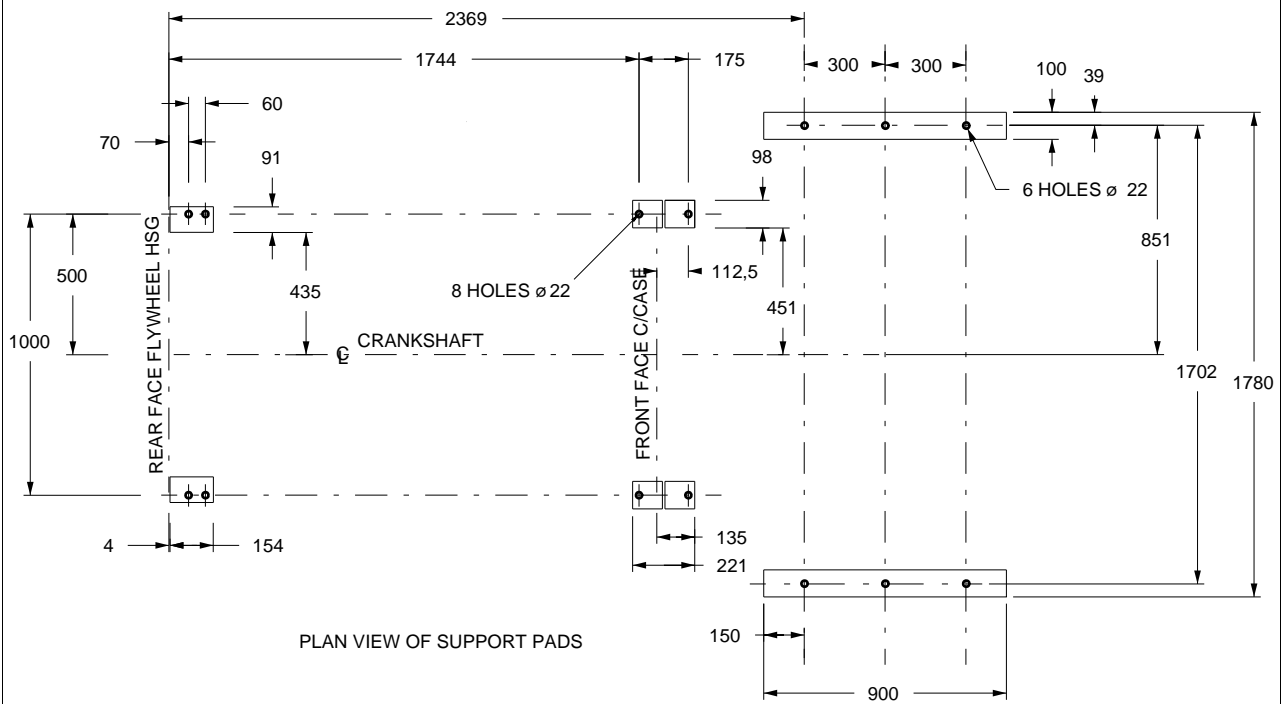

4012-46TWG3A Tropical - left view

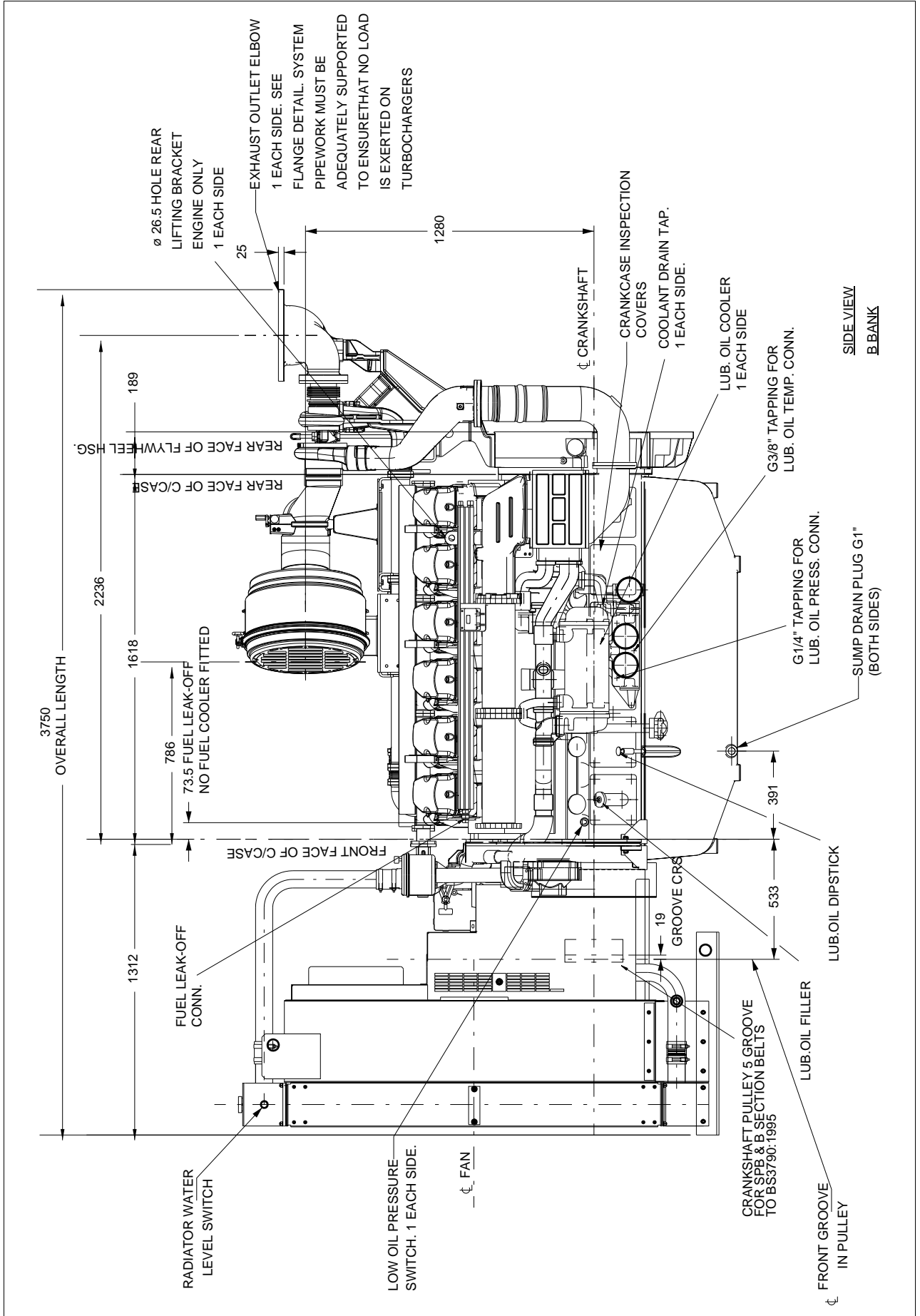

4012-46TWG3A Tropical - front view

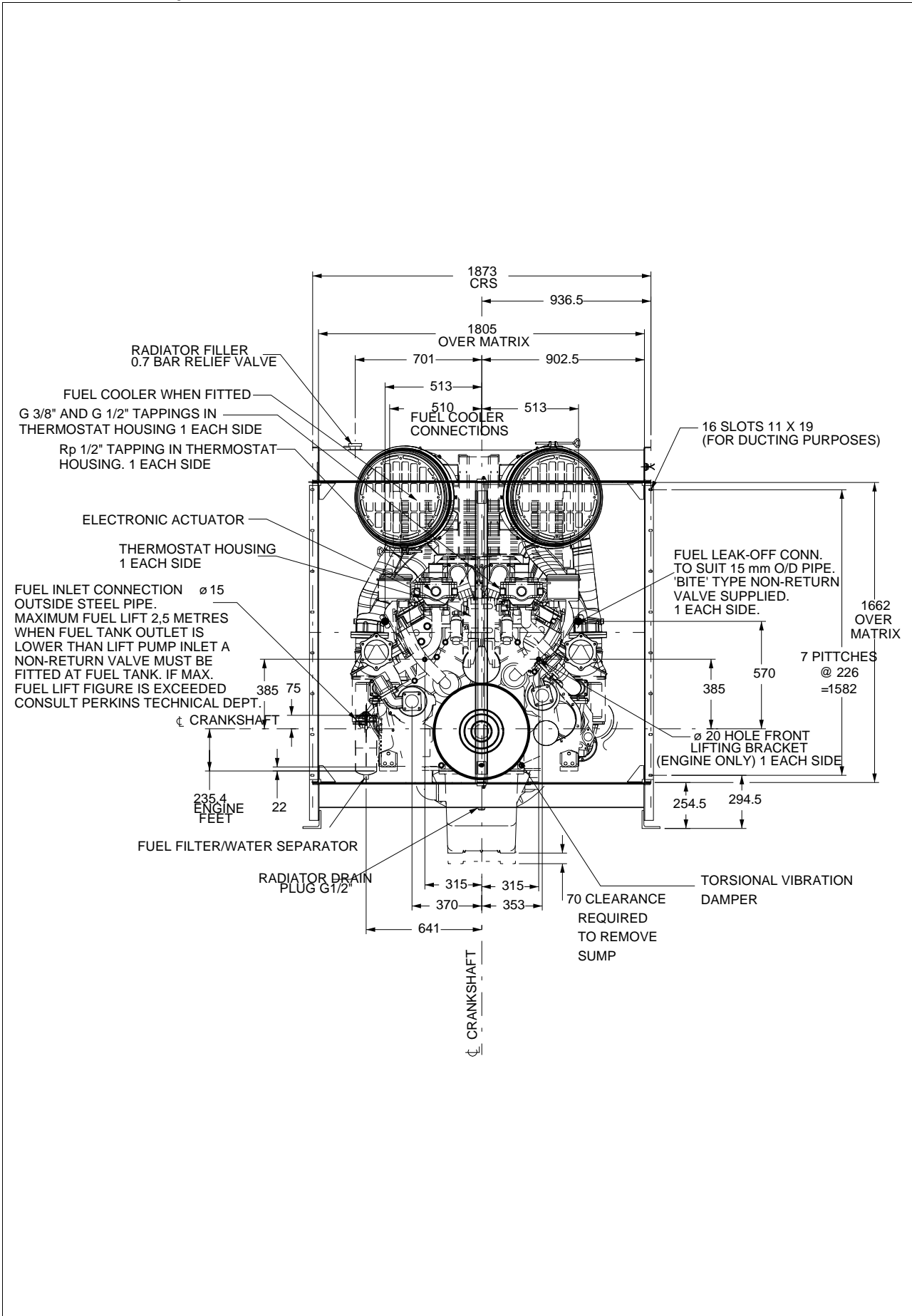

4012-46TWG3A Tropical - right view

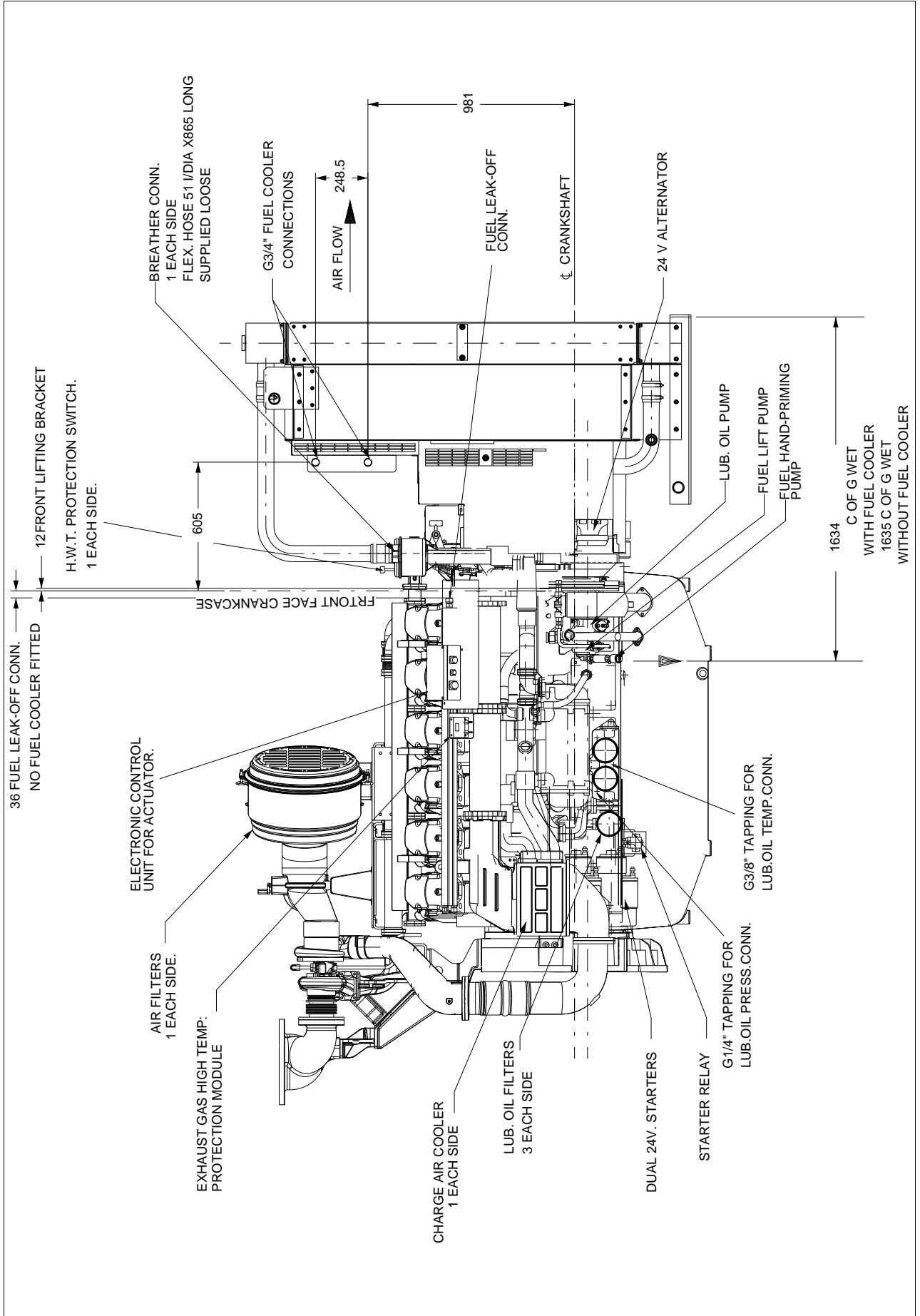

4012-46TWG3A Tropical - rear view

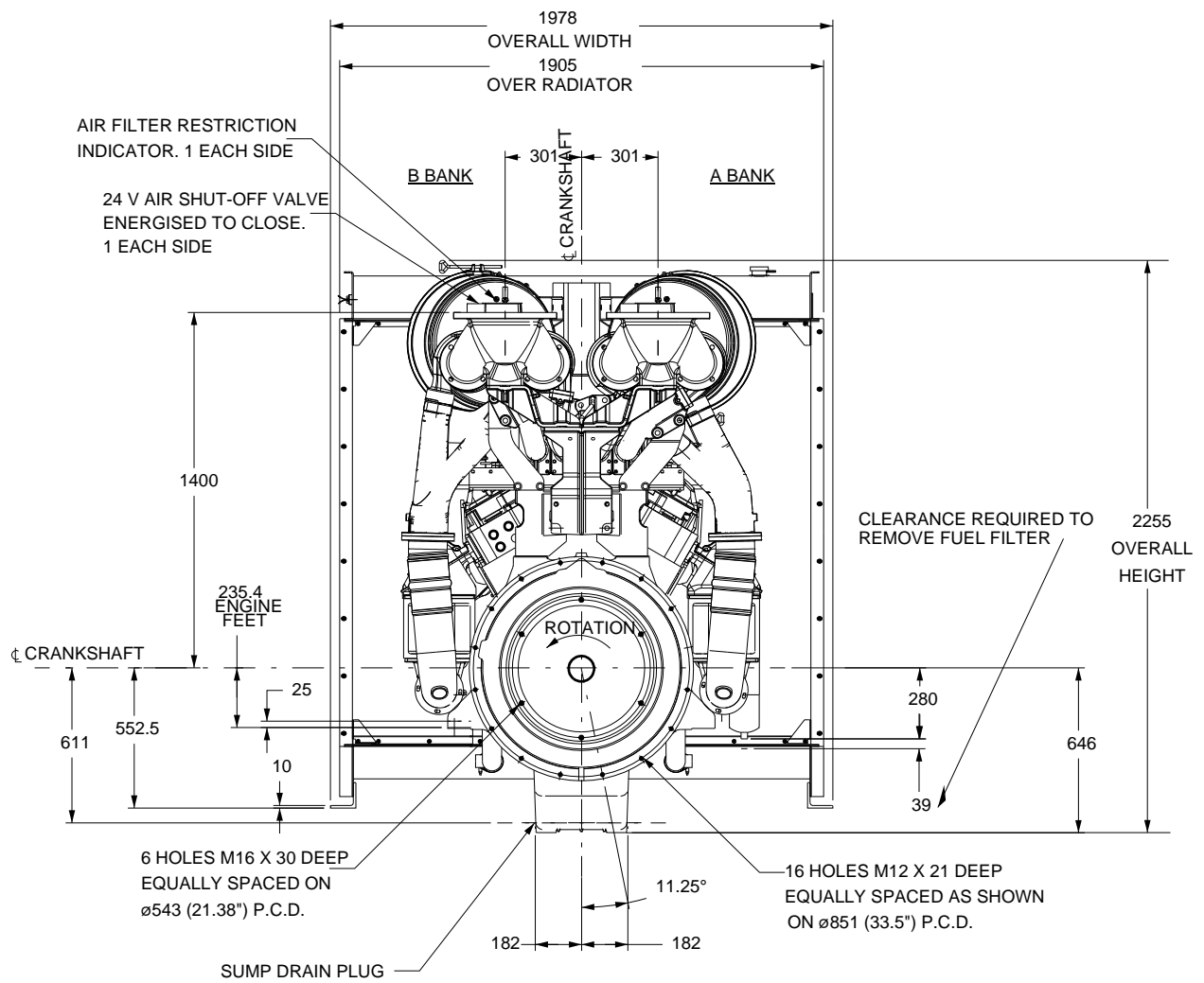

4012-46TWG3A Tropical - Support pads, exhaust outlet flange and flywheel details

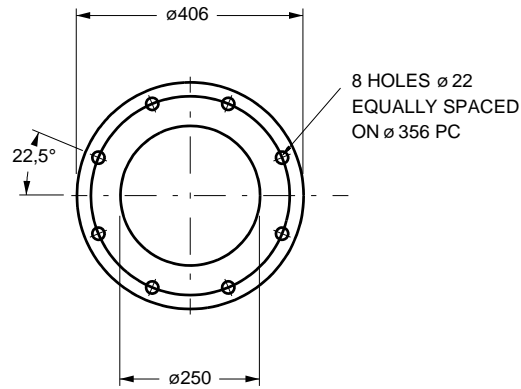

DETAIL OF EXHAUST OUTLET FLANGE
(B.S.10 TABLE D)
SCALE 1:5

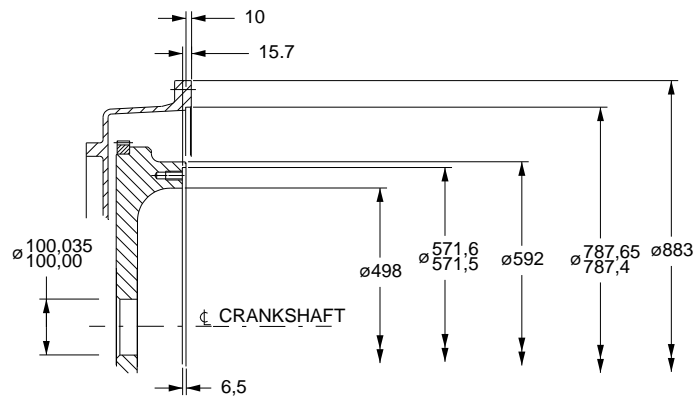

DETAIL OF SAE 518 FLYWHEEL
AND SAE 00 FLYWHEEL HOUSING
(METRIC TAPPINGS)
SCALE 1:5

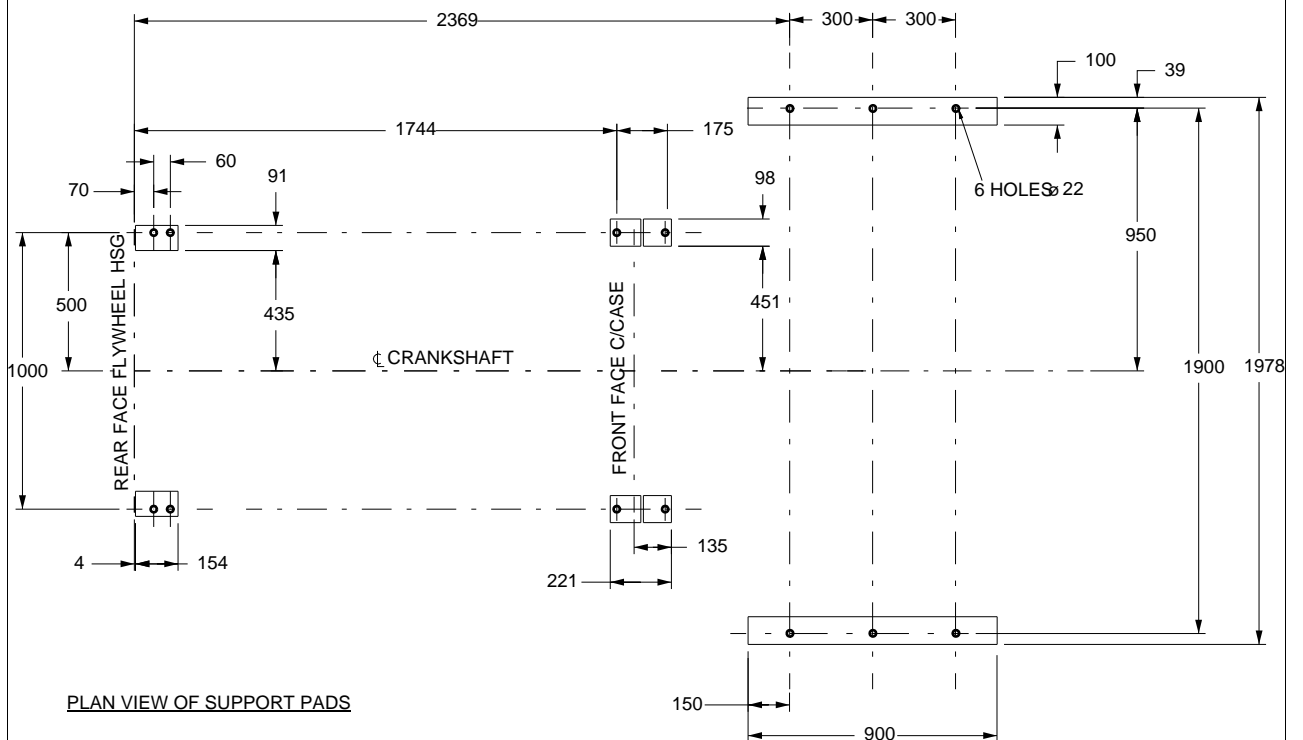

Cooling system

Recommended coolant: 50% inhibited ethylene glycol or 50% inhibited propylene glycol and 50% clean fresh water. For CHP systems and where there is no likelihood of ambient temperature below 10 °C, then clean 'soft' water may be used, treated with 1% by volume of Perkins inhibitor in the cooling system. The inhibitor is available in 1 litre bottles from all Perkins Distributors.

Maximum pressure in crankcase water jacket 170 kPa
 Maximum top tank temperature (standby) 98 °C
 Maximum static pressure on pump 70 kPa
 Maximum pressure cap setting 70 kPa

Total coolant capacity

Electronit (engine only) 73 litres
 ElectropaK
 -temperate (engine and radiator) 196 litres
 -tropical (engine and radiator) 201 litres
 Maximum permissible restriction to coolant pump flow 20 kPa
 Thermostat operating range 71 - 85 °C
 Temperature rise across the engine (standby power) with inhibited coolant 8 to 12 °C
 Shutdown switch setting 101 °C (rising)
 Coolant immersion heater capacity 2 x 4 kW

Water jacket cooling data

Coolant flow 1000 l/min
 Coolant exit temperature (max) 98 °C
 Coolant inlet temperature (min) 70 °C
 Coolant inlet temperature (max) 85 °C

Coolant pump

-speed 1.4 x engine rev/min
 -method of drive engine (gear) driven

Radiator

Face area
 -temperate 2630400 mm²
 -tropical 2967420 mm²
 Number of rows and material 226
 Fins per inch and material 7
 Width of matrix
 -temperate 1600 mm
 -tropical 1805 mm
 Height of matrix 1644 mm
 Weight (dry)
 -temperate 780 kg
 -tropical 843 kg
 Total coolant capacity
 -temperate 123 litres
 -tropical 128 litres
 Pressure cap setting (min) 69 kPa

Fan

Type engine driven
 Diameter
 -temperate 1400 mm
 -tropical 1530 mm
 Number of blades 12
 Material Aluminium
 Drive ratio
 -temperate 1:1
 -tropical 1:0,9

Cooling clearance

4012-46TWG2A - Temperate (584/470FC)

| Maximum additional restriction (duct allowance) to cooling airflow, and resultant min airflow | | | |
|---|---------------------------------|-----|---------------------|
| Description | °C | Pa | m ³ /min |
| Ambient clearance: Inhibited coolant | Dependent on radiator selection | | |
| Duct allowance | 25 | 250 | N/A |
| Minimum airflow | 25 | 250 | 1104 |

4012-46TWG2A - Tropical (584/471FC)

| Maximum additional restriction (duct allowance) to cooling airflow, and resultant min airflow | | | |
|---|----|---------------------------------|---------------------|
| Description | °C | Pa | m ³ /min |
| Ambient clearance: Inhibited coolant | 50 | Dependent on radiator selection | |
| Duct allowance | 50 | 120 | N/A |
| Minimum airflow | 50 | 120 | 1700 |

4012-46TWG3A - Temperate (584/471FC)

| Maximum additional restriction (duct allowance) to cooling airflow, and resultant min airflow | | | |
|---|----|---------------------------------|---------------------|
| Description | °C | Pa | m ³ /min |
| Ambient clearance: Inhibited coolant | 40 | Dependent on radiator selection | |
| Duct allowance | 40 | 250 | N/A |
| Minimum airflow | 40 | 250 | 1600 |

4012-46TWG3A - Tropical (584/485FC)

| Maximum additional restriction (duct allowance) to cooling airflow, and resultant min airflow | | | |
|---|----|---------------------------------|---------------------|
| Description | °C | Pa | m ³ /min |
| Ambient clearance: Inhibited coolant | 50 | Dependent on radiator selection | |
| Duct allowance | 50 | 120 | N/A |
| Minimum airflow | 50 | 120 | 1855 |

Fuel system

| | |
|--|-------------------------------------|
| Injection system | direct injection |
| Fuel injection pump | Delphi |
| Fuel Injector type | unit injector |
| Injector pressure | 23,4 MPa |
| Fuel lift pump type..... | Gerotor |
| Delivery flow..... | 1020 litres/hr |
| Heat retained in fuel to tank | |
| -4012-46TWG2A | 8,5 kW |
| -4012-46TWG3A | 9,0 kW |
| Fuel inlet temperature to be less than | 58 °C |
| Delivery pressure | 300 kPa |
| Maximum suction head at pump inlet | 24,5 kPa |
| Maximum static pressure head | see installation manual for details |
| Fuel filter spacing..... | 10 microns |
| Governing type..... | electronic |
| Governing | to ISO 8528-5 2005 |
| Torque at the governor output shaft..... | 1-631 |
| Tolerance on fuel consumption..... | to ISO 8528-1 1993 |

Fuel specification

Recommended fuel to conform to: -BS2869 1998 class A2 or BS EN590

Fuel consumption

Note: All fuel consumption figures are based on assumed fuel density of 0.862.

4012-46TWG2A - Temperate

| Designation | Fuel consumption calculated on nett rated powers | |
|-----------------------|--|-----------|
| | g/kWh | litres/hr |
| Standby | 220 | 298 |
| Prime power | 217 | 266 |
| Baseload power | 217 | 210 |
| At 75% of Prime power | | |
| At 50% of Prime power | | |

4012-46TWG2A - Tropical

| Designation | Fuel consumption calculated on nett rated powers | |
|-----------------------|--|-----------|
| | g/kWh | litres/hr |
| Standby | 220 | 298 |
| Prime power | 217 | 266 |
| Baseload power | 216 | 209 |
| At 75% of Prime power | | |
| At 50% of Prime power | | |

4012-46TWG3A - Temperate

| Designation | Fuel consumption calculated on nett rated powers | |
|-----------------------|--|-----------|
| | g/kWh | litres/hr |
| Standby | 221 | 324 |
| Prime power | 217 | 289 |
| Baseload power | 216 | 228 |
| At 75% of Prime power | | |
| At 50% of Prime power | | |

4012-46TWG3A - Tropical

| Designation | Fuel consumption calculated on nett rated powers | |
|-----------------------|--|-----------|
| | g/kWh | litres/hr |
| Standby | 222 | 325 |
| Prime power | 218 | 291 |
| Baseload power | 215 | 227 |
| At 75% of Prime power | | |
| At 50% of Prime power | | |

Electrical system

System voltage ... 24 volts
 Alternator
 -type ... insulated return
 -output ... 40 amps
 Starter
 -type ... (axial) electric
 -motor power ... 16,4 kW
 Number of teeth on
 -flywheel ... 156
 -starter motor ... 12
 Minimum cranking speed ... 120 rev/min
 Starter solenoid (24V)
 -pull in current @ -25 °C max. ... 30 amps
 -hold in current @ -25 °C max ... 9 amps
 Engine stop solenoid current ... 1,1 amps

Engine mounting

Maximum static bending moment at rear face of block ... 1356 Nm
 Maximum additional load applied to flywheel due to rotating components ... 850 kg

Centre of gravity

Bare engine (wet) 4012-46TWG2A / 4012-46TWG3A
 -forward of rear face of cylinder block ... 658 mm
 -above crankshaft centre line ... 32 mm
 ElectropaK (wet) - Temperate
 -forward of rear face of cylinder block ... 960 mm
 -above crankshaft centre line ... 32 mm
 ElectropaK (wet) - Tropical
 -forward of rear face of cylinder block ... 1286 mm
 -above crankshaft centre line ... 32 mm

Cold start recommendations

Temperature down to 0 °C (32 °F)
 Oil: ... API CG 15W40
 Starter: ... 2 x 24 volts
 Battery: ... 4 x 12V 286 Ah
 Max breakaway current: ... 1600 amps
 Cranking current: ... 810 amps
 Starting aids: ... Block heaters
 Min. mean cranking speed: ... 120 rev/min

Notes:

- The battery capacity is defined by the 20 hour rate
- The oil specification should be for the minimum ambient temperature as the oil will not be warmed by the immersion heater
- Breakaway current is dependant on battery capacity available. Cables should be capable of handling the transient current which may be up to double the steady cranking current.

Lubrication system

Recommended multigrade oil viscosity (15W40) which adequately meets the specifications of API CH4. For further details refer to the engine OMM.

Lubricating oil capacity

Total system ... 177 litres
 Sump maximum ... 157,5 litres
 Sump minimum ... 115 litres
 Oil temperature at normal operating conditions ... 95 °C
 Oil temperature (in rail) - maximum continuous operation .. 105 °C

Lubricating oil pressure

minimum ... 340 kPa
 At rated speed ... 450 kPa
 Oil relief opens ... 400 kPa
 Oil filter screen spacing ... 20 microns
 Sump drain plug tapping size ... G1
 Lubricating oil pump speed ... 1.4 x engine rev/min
 Lubricating oil pump drive method ... engine driven
 Shutdown switch - pressure setting (where fitted) 193 kPa (falling)

Normal operating angles

-front and rear ... 5°
 -side tilt ... 10°

| Oil consumption (prime power) | | 4012-46TWG2A | 4012-46TWG3A |
|--|--------|--------------|--------------|
| After running-in (typically after 250 hours) | g/kWhr | 0.7 | 0.7 |
| Oil flow rate from oil pump | l/s | 7 | 7 |

Noise levels

The figures for total noise levels are typical for an engine running at the standby power rating in a semi-reverberant environment and measured at a distance of one metre from the periphery of the engine (sound pressure level re: -20×10^{-6} Pa).

Ambient noise level..... 70 d(B)A

Octave analysis

The following diagrams show maximum noise level.

Noise data 4012-46TWG3A, 1800 rev/min 1263 kWb with radiator 584/471FC

| Position | SPL dBA |
|----------|---------|
| 1 | 114.5 |
| 2 | 113.0 |
| 3 | 114.0 |
| 4 | 112.0 |
| 5 | 113.0 |
| 6 | 114.0 |

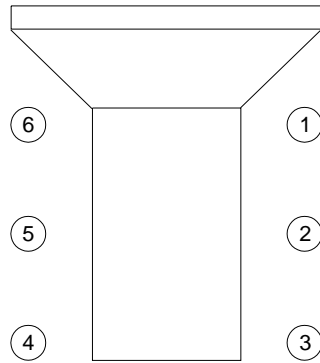

Frequency analysis at point 6

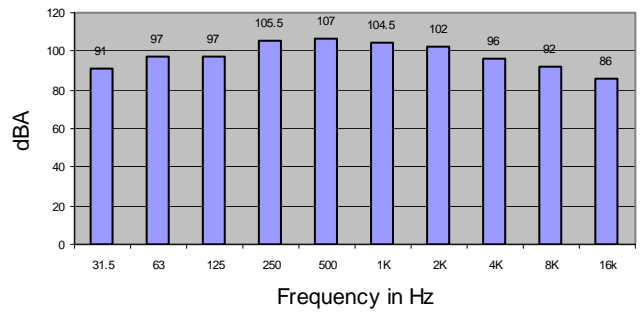

Noise data 4012-46TWG3A, 1800 rev/min 1263 kWb with radiator 584/485FC

| Position | SPL dBA |
|----------|---------|
| 1 | 114.0 |
| 2 | 114.0 |
| 3 | 113.0 |
| 4 | 112.0 |
| 5 | 113.5 |
| 6 | 113.0 |

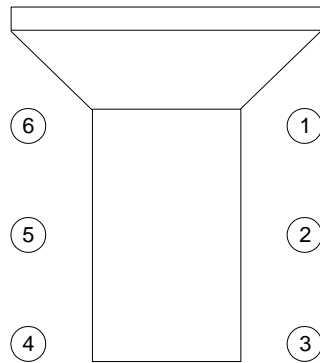

Frequency analysis at point 1

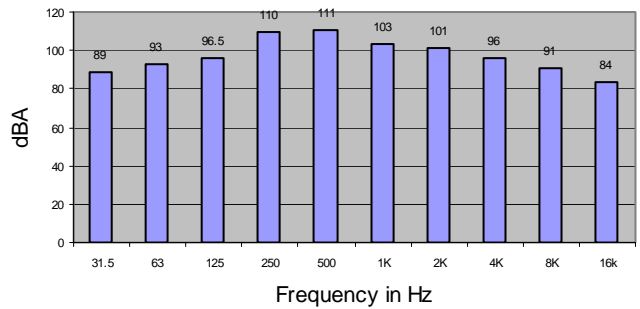

Note: The information given on this Technical Data Sheet is for standard ratings only. For ratings other than those shown, please contact Perkins Engines Company Limited.

Load acceptance (cold)

| | |
|--|---------------------|
| 4012-46TWG2A (prime %) | 72 |
| 4012-46TWG3A (prime %) | 65 |
| Engine block temperature (cold) | 45 °C |
| Ambient temperature | 25 °C |
| Governing mode | Isochronous |
| Alternator inertia | 50 kgm ² |
| Under frequency roll off (UFRO) point set to | 49 Hz |
| UFRO rate set to | 16 V/Hz |
| LAM on/off | on |

Notes:

- All test were conducted using an engine installed and serviced to Perkins Engine Company Limited recommendations
- Applied load is a percentage of the generator electrical output efficiencies as published in the general installation section of this data sheet.



Perkins Engines Company Limited
Peterborough PE1 5NA United Kingdom
Telephone +44 (0) 1733 583000
Fax +44 (0) 1733 582240
www.perkins.com

All information in the document is substantially correct at the time of printing but may be subsequently altered by the company.

Distributed by